



DN500 Pneumatic Marine Butterfly Valve BV High Temperature valve High Efficiency Emission Reduction

Our Product Introduction

Basic Information

- Place of Origin: China
- Brand Name: FABIA
- Certification: ISO9001, BV, CCS, DNV
- Model Number: 2 inch 100 inch
- Minimum Order Quantity: 1 set
- Price: Negotiable
- Packaging Details: Cartons/Wooden cases
- Delivery Time: 15-30 work days
- Payment Terms: L/C, D/A, D/P, T/T, MoneyGram, Western Union
- Supply Ability: 100-1000 set per week



Product Specification

- Product Name: Marine Butterfly Valve
- Valve Application: Ventilation
- Valve Material: Stainless Steel
- Valve Connection: Flanged
- Valve Operation: Pneumatic
- Valve Certification: BV, DNV, CCS
- Valve Pressure: ≤ 0.25 Mpa
- Valve Seal: Stainless Steel
- Valve Size: 2-100 Inch
- Valve Temperature: 500
- Valve Type: Butterfly
- Highlight: **DN500 Marine Butterfly Valve, Emission Reduction Marine Butterfly Valve, High Efficiency Marine Butterfly Valve**



More Images

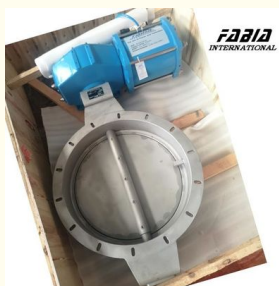

for more products please visit us on fbballvalve.com

Product Description

DN500 Pneumatic Marine Butterfly Valve BV High Temperature valve High Efficiency Emission Reduction

1. Description:

In the Marine field, FB-D-3 series butterfly valves are mainly used to deal with diesel engine exhaust gas treatment system, through the supporting actuator to adjust or cut off the exhaust gas in the system aisle, so as to achieve Marine nitrogen oxide emissions to meet the requirements of relevant standards. At present, the main application of waste gas treatment systems are SCR system, ICER system, etc.

In addition, FB-D-3 series butterfly valves are also widely used in the road industry, such as the exhaust gas exhaust pipe system produced by the boiler in steel smelting, the catalytic combustion equipment pipe system in VOCs (RTO combustion furnace) and the exhaust gas pipe system produced by other combustion equipment.

2. Specification:

FABIA Valve Parameter List	
Valve type:	Flange type heavy-duty ventilation butterfly valve
Size:	2inch 100 inch
Material:	316/316L/304/304L/ Corten
Connection type:	Flange Connection
Driving model:	Manual/Worm gear drive/Pneumatic/Electric
Pressure rating:	≤0.25Mpa
Temperature:	-≤500
Model:	FB-D-3.....

3. Features:

Simple and light in structure

Suitable for low pressure air or other gas flow, pressure control and high temperature gas

the main structural components of the valve are welded

CCS&DNV Type approval certificate, BV French Classification Society Factory approval certificate and product type approval certificate.

High Efficiency Emission Reduction: Optimized design significantly reduces ship emissions, complying with stringent environmental regulations.

Durable and Reliable: Made of high-quality materials with a robust design to ensure long-term stable operation, reducing maintenance frequency and costs.

Smart Control: Equipped with advanced control systems for automated operation, enhancing operational efficiency and safety.

Multiple Safety Guarantees: Incorporates multiple layers of safety protection mechanisms to ensure safe and reliable valve operation.

Global Standard Certification: Certified by international authorities, ensuring product quality and performance meet global standards.

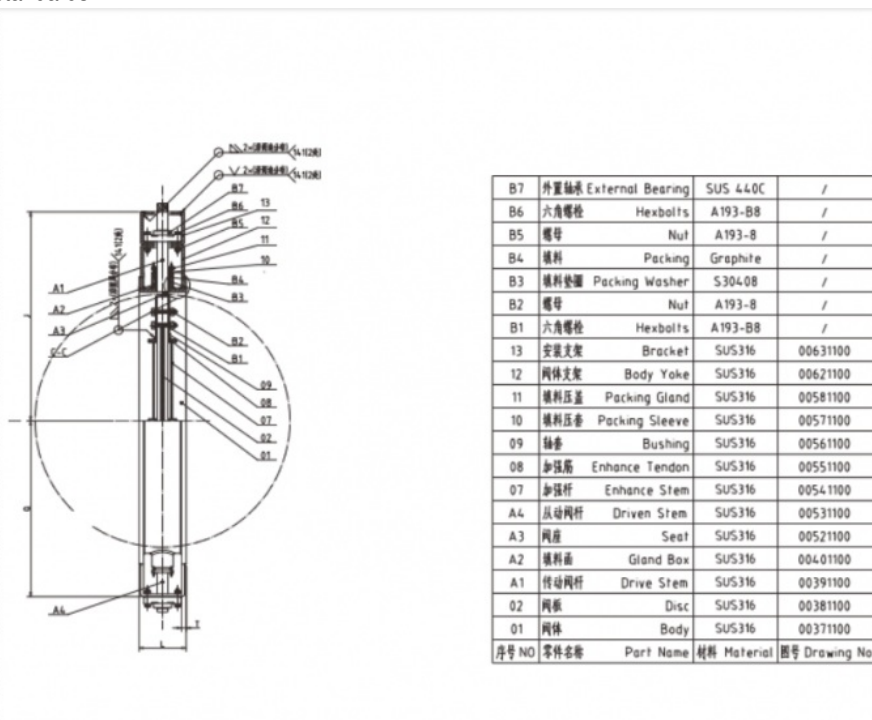

编号 NO.	NPS-DN		主要外形尺寸 Main Outer Dimension								法兰连接尺寸 Main Outer Dimension			
			L	ΦG	J	Q	OP	M	H	H1	T	ΦD	ΦD1	N-ΦB
1	6"	150	150	N/A	332.5	232.5	14X14	17	100	200	15	265	225	8-Φ18
2	8"	200	150	N/A	360	260	14X14	17	100	200	15	320	280	8-Φ18
3	10"	250	150	N/A	387.5	287.5	14X14	17	100	200	15	375	335	12-Φ18
4	12"	300	150	N/A	420	320	17X17	20	100	200	15	440	395	12-Φ22
5	14"	350	150	N/A	445	345	17X17	20	100	200	15	490	445	12-Φ22
6	16"	400	150	N/A	470	370	22X22	25	100	200	20	540	495	16-Φ22
7	18"	450	200	N/A	497.5	397.5	22X22	25	100	200	20	595	550	16-Φ22
8	20"	500	200	N/A	672.5	522.5	22X22	25	150	350	20	645	600	20-Φ22
9	24"	600	200	N/A	727.5	577.5	27X27	30	150	350	20	755	705	20-Φ26
10	28"	700	200	N/A	780	630	27X27	30	150	350	20	860	810	24-Φ26
11	32"	800	260	N/A	837.5	687.5	27X27	30	150	350	24	975	920	24-Φ30
12	36"	900	260	N/A	887.5	737.5	36X36	40	150	350	24	1075	1020	24-Φ30
13	40"	1000	260	N/A	937.5	787.5	36X36	40	150	350	24	1175	1120	28-Φ30
14	48"	1200	260	N/A	1087.5	887.5	36X36	40	200	400	24	1375	1320	32-Φ30
15	56"	1400	260	N/A	1187.5	987.5	36X36	40	200	400	24	1575	1520	36-Φ30
16	60"	1500	300	N/A	1295	1095	46X46	45	200	400	30	1790	1730	40-Φ30



FABIA[®] Fabia Valve Industry (Suzhou) Co., Ltd.
INTERNATIONAL

+8618913247051/+8618912658215/+8618260178084

sales@fabia-china.com

fbballvalve.com

Room 1305, Building 3, Jundi Business Plaza, No.3, Weihua Road, Suzhou Industrial Park